

# EUROMOLD®

INTERFACE E - 5/8"  
MEDIUM VOLTAGE SEPARABLE  
CONNECTORS AND BUSHINGS

CATALOGUE 2024





# COMPANY PRESENTATION



## EUROMOLD

Euromold is the leading European specialised designer, manufacturer and distributor of prefabricated cable accessories for medium voltage energy distribution. Euromold provides a complete range of accessories for underground cables: premoulded EPDM rubber connectors for cables and epoxy bushings for transformers and switchgear, as well as a large range of cold-shrinkable terminations and joints from 12 to 42 kV.

Euromold is also the manufacturer of electrical components for the high voltage accessories of the Nexans group.

## ISO 9001 Certificate

Since 1992, Euromold's commitment to quality is demonstrated by its ISO 9001 certification.

## International standards

All our products meet the International standards like CENELEC HD 629.1, CENELEC EN 50180, IEC 60137, IEC 60502-4... or country specifications. Official certificates, CESI, KEMA, ATEX... prove the conformity of our products. Long duration tests of existing or new products are continuously performed in our test fields.

## Laboratory accreditation

Since June 2000, Euromold's independent ELAB laboratory obtained the BELAC accreditation no.144-TEST conform with the European standards for laboratories ISO 17025 for electrical testing of low and medium voltage cable accessories according to the international standards EN 50393, IEC 60502-4, IEC 61442 and HD 629.



While every care is taken to ensure that the information contained in this publication is correct, no legal responsibility can be accepted for any inaccuracy. Nexans Network Solutions N.V. - Div. Euromold reserves the right to alter or modify the characteristics of its products described in this catalogue as standards and technology evolve.

# SEPARABLE CONNECTORS AND BUSHINGS

INTERFACE E - 5/8"

## TABLE OF CONTENTS

- 784TB - tee connector
- 800PB-58 - coupling connector
- 804PB-58 - coupling connector
- 800SA-58 - surge arrester
- 750S1, 775S1 & 775T1 - equipment bushing
- Accessories
- Possible arrangements

## INTERFACE E - 5/8"

Dimensions according to IEEE std. 386 (in mm, except where noted).

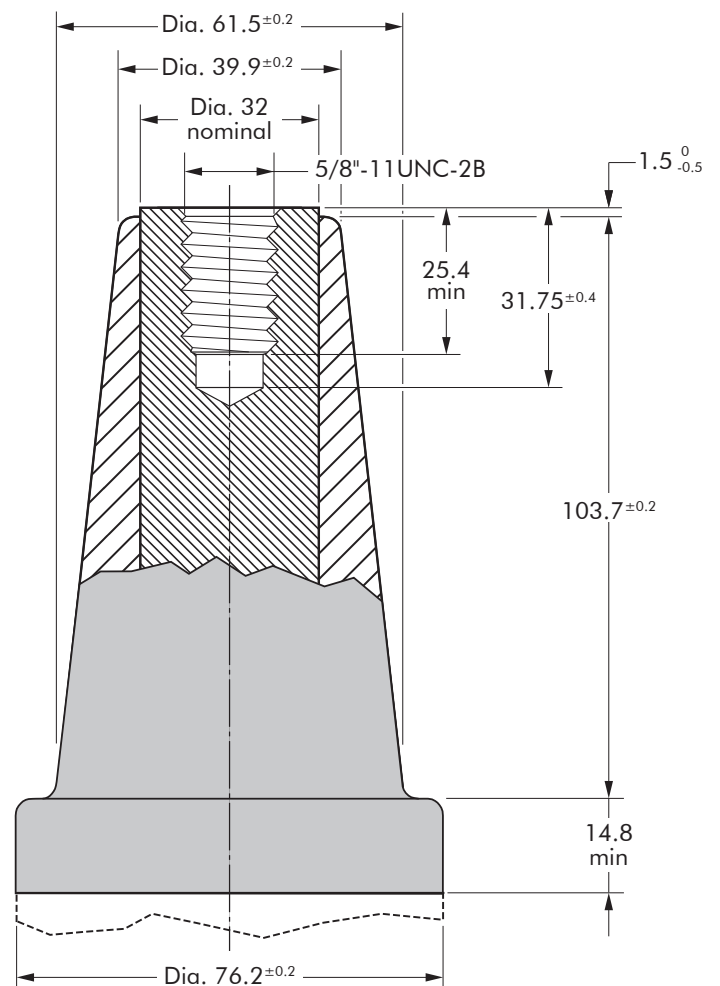

In mm.

# CONNECTING POSSIBILITIES

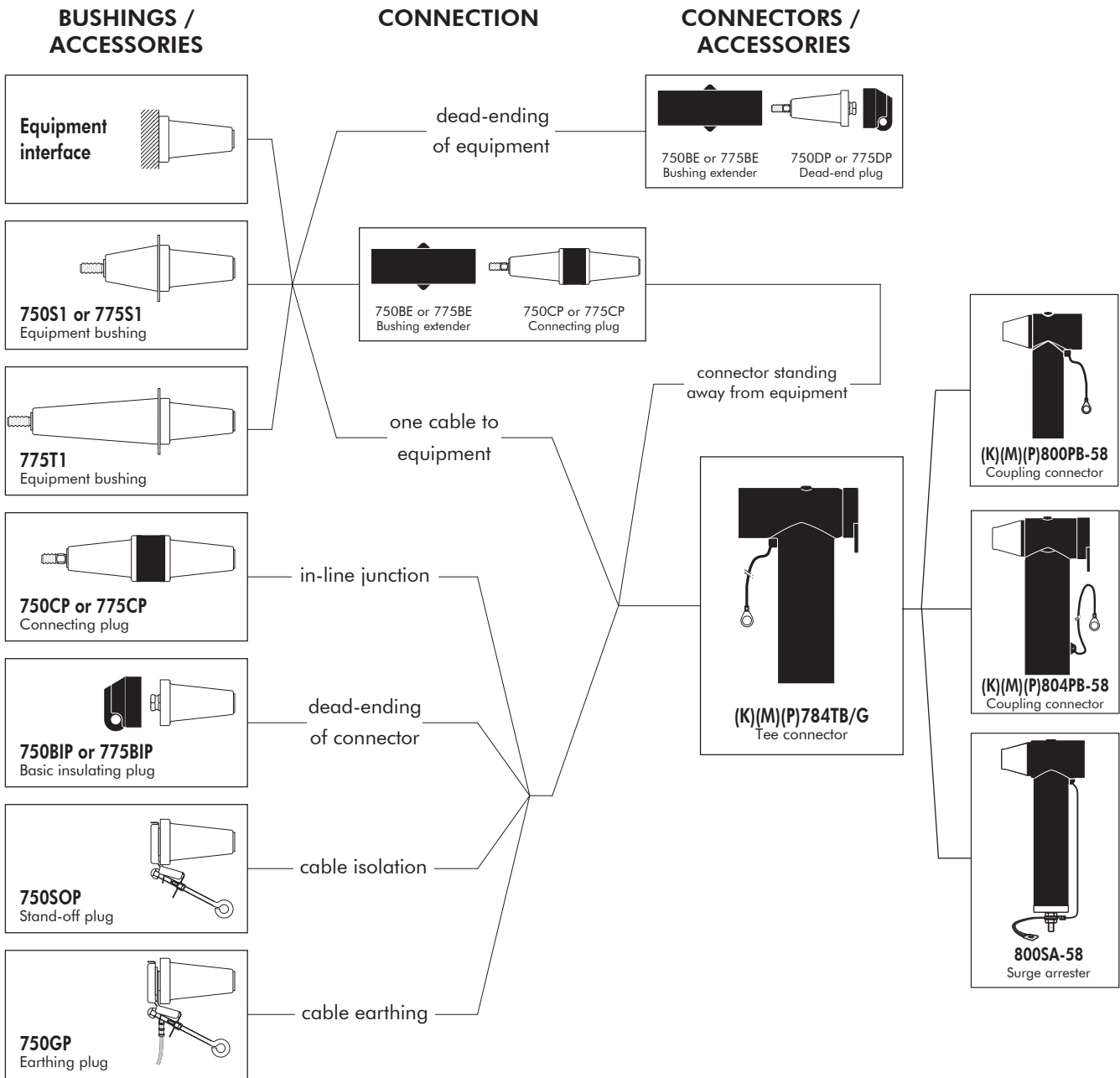

## APPLICATION

Separable tee shape connector (bolted type) designed to connect polymeric insulated cable to equipment (transformers, switchgear, motors, ...). Also connects cable to cable when using the appropriate mating parts.

## TECHNICAL CHARACTERISTICS

- The thick conductive EPDM jacket provides a total safe to touch screen.
- Each separable connector is tested for AC withstand and partial discharge prior to leaving the factory.



## DESIGN

Separable connector comprising:

1. Conductive EPDM insert.
2. Conductive EPDM jacket.
3. Insulating EPDM layer moulded between the insert and the jacket.
4. Type E 5/8" interface as described by IEEE 386.
5. Conductor contact.
6. Basic insulating plug 858 BIPA (with VD point).
7. Cable reducer.
8. Conductive rubber cap.
9. Stud+flange nut 5/8".
10. Earthing lead.

The screen break design enables cable outer sheath testing without removing or dismantling the connector.

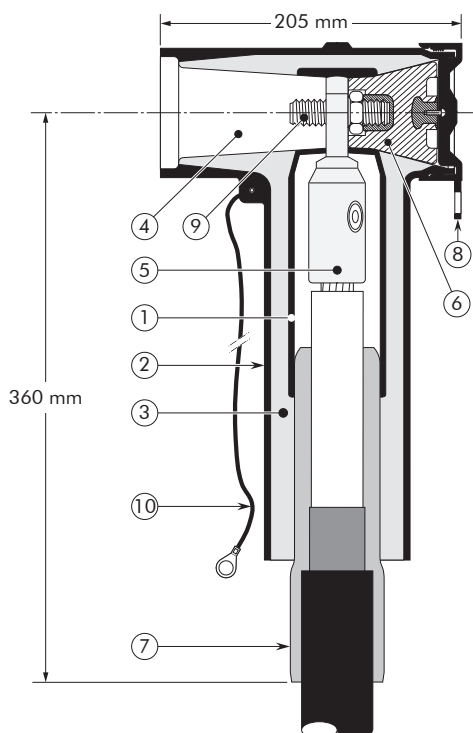

6/10 (12) kV  
6.35/11 (12) kV  
8.7/15 (17.5) kV  
12/20 (24) kV  
12.7/22 (24) kV  
18/30 (36) kV  
19/33 (36) kV  
20.8/36 (42) kV

**Up to 42 kV**  
**Up to 800 A**

**EUROMOLD®**

## SPECIFICATIONS AND STANDARDS

The 784TB separable connector meets the requirements of CENELEC HD 629.1.

Separable connector type	Voltage $U_m$ (kV)	Current $I_r$ (A) When installed on an appropriate equipment bushing	Conductor sizes (mm <sup>2</sup> )	
			min	max
784TB/G	12	800	50	630
K784TB/G	24	800	35	630
M784TB/G	36	800	35	630
P784TB/G	42	800	35	630

04/2024

## KIT CONTENTS

The complete (K)(M)(P)784TB/G tee connector kit comprises 3x the following components:

The kit also comprises silicone grease, field control mastic, gloves, wipers, roll adhesive tape, installation instructions and venting rod.

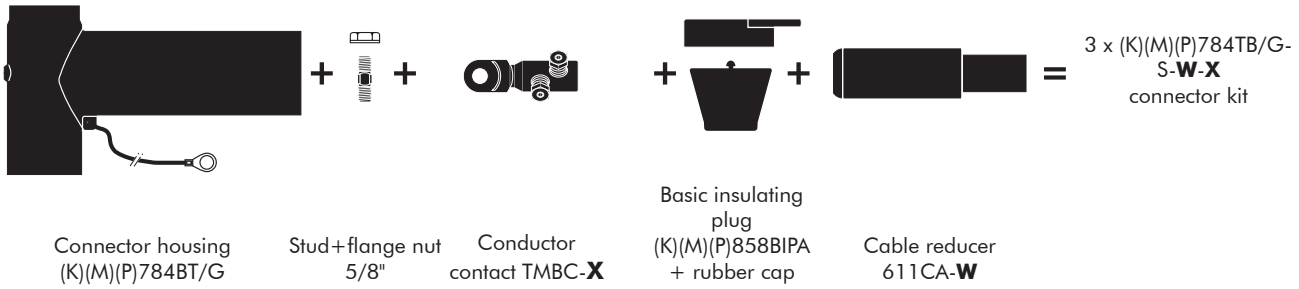

## ORDERING INSTRUCTIONS

To order the tee connector, select the ordering part number which gives you the best centring of your core insulation diameter and substitute **X** using table X, according to your conductor size and type. Add a 'K' for use up to 24 kV, add an 'M' for use up to 36 kV, add a 'P' for use up to 42 kV.

### EXAMPLE:

The copper wire screened cable is 36 kV, 240 mm<sup>2</sup> stranded aluminium with a diameter over core insulation of 37.0 mm. Order 3 x M784TB/G-S-32-95.300UN5

TABLE W

Ordering part number	Dia. over core insulation (mm)	
	min	max
3 x 784TB/G-S-15-X	16.0	22.0
3 x 784TB/G-S-19-X	20.0	26.5
3 x 784TB/G-S-22-X	23.5	31.0
3 x 784TB/G-S-27-X	28.5	37.5
3 x 784TB/G-S-32-X	34.0	42.5
3 x 784TB/G-S-37-X	39.0	48.5
3 x 784TB/G-S-43-X	45.5	56.0

TABLE X

Conductor sizes (mm <sup>2</sup> )	Aluminium and copper conductor	
	Bolted	
35	16.95UN5	95.300UN5
50		
70		
95		
120		
150	400.630UN5	
185		
240		
300		
400		
500		
630		

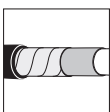

For use with copper tape screened cables. Order: Kit MT.



For use with other cable types. Please contact our representative.



For applications outdoors and in humid climate. Order: +MWS.



For use in potentially explosive atmospheres (for 12 kV max). Order: ATEX-IECEx



Components can be ordered individually.

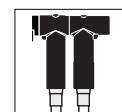

Multiple cable arrangement possible. Please contact our representative.

## APPLICATION

Separable tee shape connector (bolted type) designed to connect polymeric insulated cable to equipment (transformers, switchgear, motors, ...). Also connects cable to cable when using the appropriate mating parts.

## TECHNICAL CHARACTERISTICS

- The thick conductive EPDM jacket provides a total safe to touch screen.
- Each separable connector is tested for AC withstand and partial discharge prior to leaving the factory.



## DESIGN

Separable connector comprising:

1. Conductive EPDM insert.
2. Conductive EPDM jacket.
3. Insulating EPDM layer moulded between the insert and the jacket.
4. Type E 5/8" interface as described by IEEE 386.
5. Conductor contact.
6. Basic insulating plug 858 BIPA (with VD point).
7. Cable reducer.
8. Conductive rubber cap.
9. Stud+flange nut 5/8".
10. Earthing lead.

The screen break design enables cable outer sheath testing without removing or dismantling the connector.

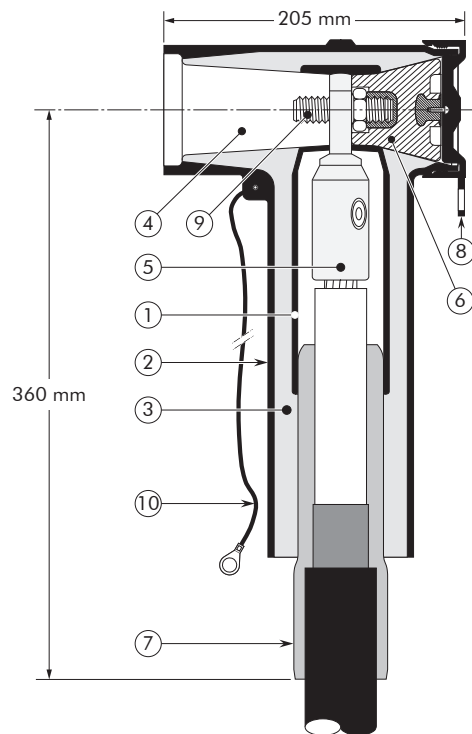

6/10 (12) kV  
6.35/11 (12) kV  
8.7/15 (17.5) kV  
12/20 (24) kV  
12.7/22 (24) kV  
18/30 (36) kV  
19/33 (36) kV  
20.8/36 (42) kV

**Up to 42 kV**  
**Up to 1250 A**

**EUROMOLD®**

## SPECIFICATIONS AND STANDARDS

The 784TB separable connector meets the requirements of CENELEC HD 629.1.

Separable connector type	Voltage $U_m$ (kV)	Current $I_r$ (A) When installed on an appropriate equipment bushing	Conductor sizes (mm <sup>2</sup> )	
			min	max
784TB/G	12	1250	50	630
K784TB/G	24	1250	35	630
M784TB/G	36	1250	35	630
P784TB/G	42	1250	35	630

04/2024



## KIT CONTENTS

The complete (K)(M)(P)784TB/G tee connector kit comprises 3x the following components:

The kit also comprises silicone grease, field control mastic, gloves, wipers, roll adhesive tape, installation instructions and venting rod.

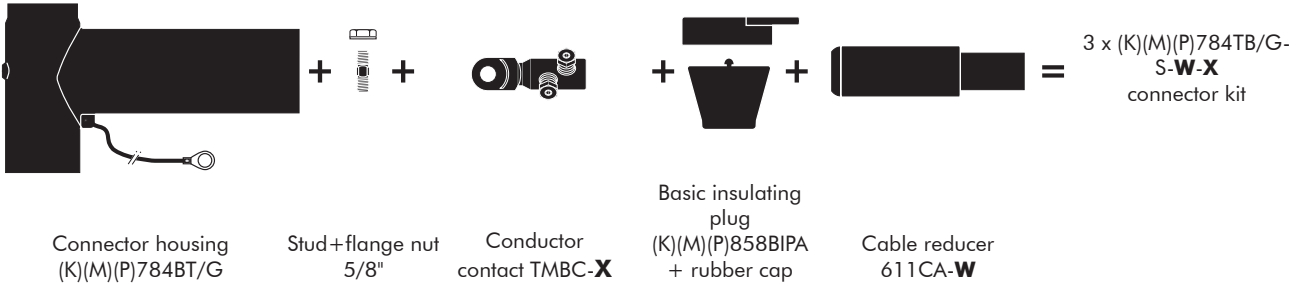

## ORDERING INSTRUCTIONS

To order the tee connector, select the ordering part number which gives you the best centring of your core insulation diameter and substitute **X** using table X, according to your conductor size and type. Add a 'K' for use up to 24 kV, add an 'M' for use up to 36 kV, add a 'P' for use up to 42 kV.

### EXAMPLE:

The copper wire screened cable is 36 kV, 240 mm<sup>2</sup> stranded aluminium with a diameter over core insulation of 37.0 mm. Order 3 x M784TB/G-S-32-95.300UN5.

TABLE W

Ordering part number	Dia. over core insulation (mm)	
	min	max
3 x 784TB/G-S-15- <b>X</b>	16.0	22.0
3 x 784TB/G-S-19- <b>X</b>	20.0	26.5
3 x 784TB/G-S-22- <b>X</b>	23.5	31.0
3 x 784TB/G-S-27- <b>X</b>	28.5	37.5
3 x 784TB/G-S-32- <b>X</b>	34.0	42.5
3 x 784TB/G-S-37- <b>X</b>	39.0	48.5
3 x 784TB/G-S-43- <b>X</b>	45.5	56.0

TABLE X

Conductor sizes (mm <sup>2</sup> )	Aluminium and copper conductor		
	Bolted		
35	16.95UN5		
50			
70			
95		95.300UN5	
120			
150			
185			
240			
300			
400			
500			
630			
			400.630UN5

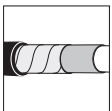

For use with copper tape screened cables. Order: Kit MT.



For use with other cable types. Please contact our representative.



For applications outdoors and in humid climate. Order: +MWS.



For use in potentially explosive atmospheres (for 12 kV max). Order: ATEX-IECEx



Components can be ordered individually.

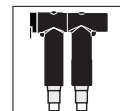

Multiple cable arrangement possible. Please contact our representative.

### APPLICATION

Separable coupling connector (bolted type) for dual cable arrangement. It has been designed to be used with 784TB separable tee connector.

### TECHNICAL CHARACTERISTICS

- A thick conductive EPDM jacket provides a total safe to touch screen.
- Each separable connector is tested for AC withstand and partial discharge prior to leaving the factory.



### DESIGN

1. Interface designed to fit 784TB connector.
2. Contact rod type 5/8".
3. Conductor connector.
4. Conductive EPDM insert.
5. Conductive EPDM jacket.
6. Insulating EPDM layer moulded between the insert and the jacket.
7. Cable reducer.
8. Conductive EPDM cap.
9. Basic insulating plug 858BIPA (with VD point).
10. Earthing lead.

The screen break design enables cable outer sheath testing without removing or dismantling the connector.

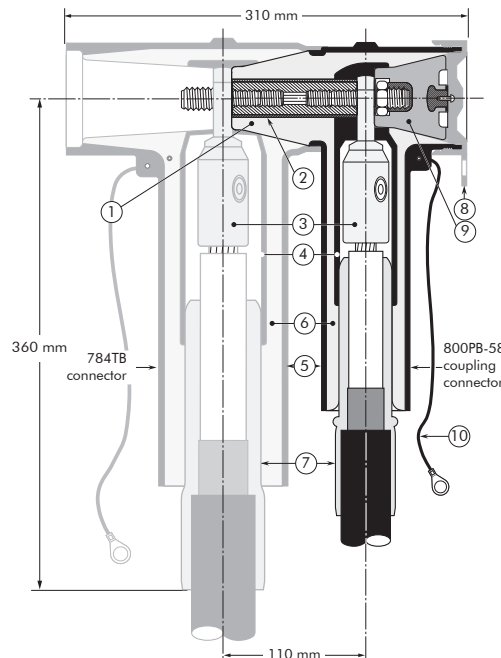

6/10 (12) kV  
6.35/11 (12) kV  
8.7/15 (17.5) kV  
12/20 (24) kV  
12.7/22 (24) kV  
18/30 (36) kV  
19/33 (36) kV  
20.8/36 (42) kV

**Up to 42 kV**  
**1250 A**

**EUROMOLD®**

### SPECIFICATIONS AND STANDARDS

The 800PB-58 coupling connector meets the requirements of CENELEC HD 629.1.

Separable connector type	Voltage $U_m$ (kV)	Current $I_r$ (A)	Conductor sizes	
			min	max
800PB/G-58	12	1250	16	300
K800PB/G-58	24	1250	16	300
M800PB/G-58	36	1250	35	240
P800PB/G-58	42	1250	35	240

## KIT CONTENTS

The complete (K)(M)(P) 800PB-58/G coupling connector kit comprises 3 x the following components:

The kit also comprises silicone grease, installation cone, gloves, wipers, roll adhesive tape and installation instructions.

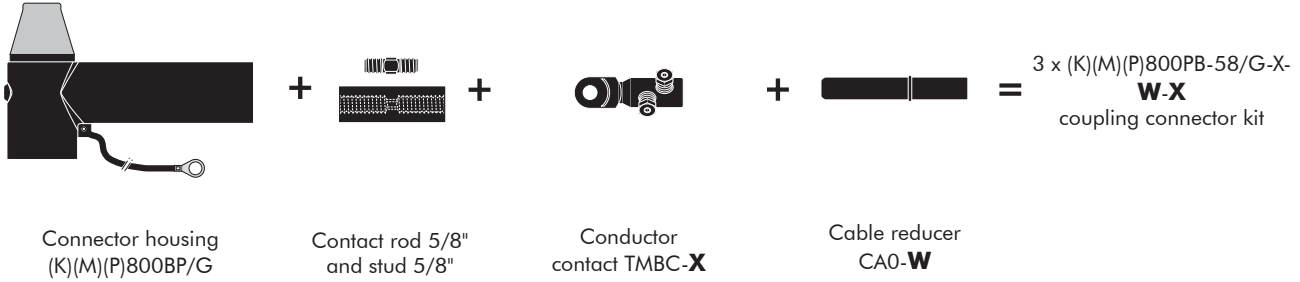

## ORDERING INSTRUCTIONS

To order the coupling connector, select the ordering part number which gives you the best centring of your core insulation diameter and substitute **X** using table X, according to your conductor size and type. Add a 'K' for use up to 24 kV, add an 'M' for use up to 36 kV, add a 'P' for use up to 42 kV.

TABLE W

Ordering part number	Dia. over core insulation (inches)	
	min	max
3 x 800PB/G-58-011-X	12.0	19.0
3 x 800PB/G-58-015-X	16.0	26.5
3 x 800PB/G-58-018-X	19.0	32.6
3 x 800PB/G-58-021-X	22.0	34.6
3 x 800PB/G-58-027-X	28.5	37.5

### EXAMPLE:

The cable is 24 kV, 185 mm<sup>2</sup> compact stranded copper with a diameter over core insulation of 27.5 mm.  
Order 3 x K800PB/G-58-018-95.300UN5 coupling connector kit.

TABLE X

Conductor sizes (mm <sup>2</sup> )	Aluminium and copper conductor	
	Bolted	
16	16.95UN5	
25		
35		
50		
70		
95	95.300UN5	
120		
150		
185		
240		
300		

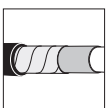

For use with copper tape screened cables.  
Order: Kit MT.

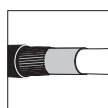

For use with copper wire screened cables.  
No earthing device is necessary.



For use with other cable types.  
Please contact our representative.



For outdoor applications.  
Order: +MWS.



For use in potentially explosive atmospheres (for 12 kV max).  
Add -/ATEX to part number.

### APPLICATION

Separable coupling connector for dual cable arrangement. It has been designed to be used with 784TB separable tee connectors.

### TECHNICAL CHARACTERISTICS

- A thick conductive EPDM jacket provides a total safe to touch screen.
- Each separable connector is tested for AC withstand and partial discharge prior to leaving the factory.



### DESIGN

1. Interface designed to fit 784TB connector.
2. Contact rod type 5/8".
3. Conductor connector (hexagonal crimping, deep indent crimping or bolted).
4. Conductive EPDM insert.
5. Conductive EPDM jacket.
6. Insulating EPDM layer moulded between the insert and the jacket.
7. Cable reducer.
8. Conductive EPDM cap.
9. Basic insulating plug 858BIPA (with VD point).
10. Earthing lead.

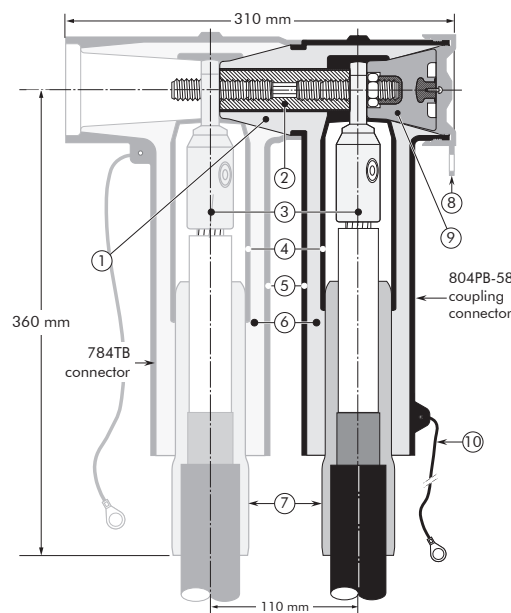

6/10 (12) kV  
6.35/11 (12) kV  
8.7/15 (17.5) kV  
12/20 (24) kV  
12.7/22 (24) kV  
18/30 (36) kV  
19/33 (36) kV  
20.8/36 (42) kV

**Up to 42 kV**  
**1250 A**

**EUROMOLD®**

The screen break design enables cable outer sheath testing without removing or dismantling the connector.

### SPECIFICATIONS AND STANDARDS

The 804PB-58 coupling connector meets the requirements of CENELEC HD 629.1.

Separable connector type	Voltage $U_m$ (kV)	Current $I_r$ (A)	Conductor sizes (mm <sup>2</sup> )	
			min	max
804PB/G-58	12	1250	50	630
K804PB/G-58	24	1250	35	630
M804PB/G-58	36	1250	35	630
P804PB/G-58	42	1250	35	630

04/2024

## KIT CONTENTS

The complete (K)(M)804PB/G-58 coupling connector kit comprises 3 x the following components:

The kit also comprises silicone grease, field control mastic, gloves, wipers, roll adhesive tape, installation instructions and crimp chart.

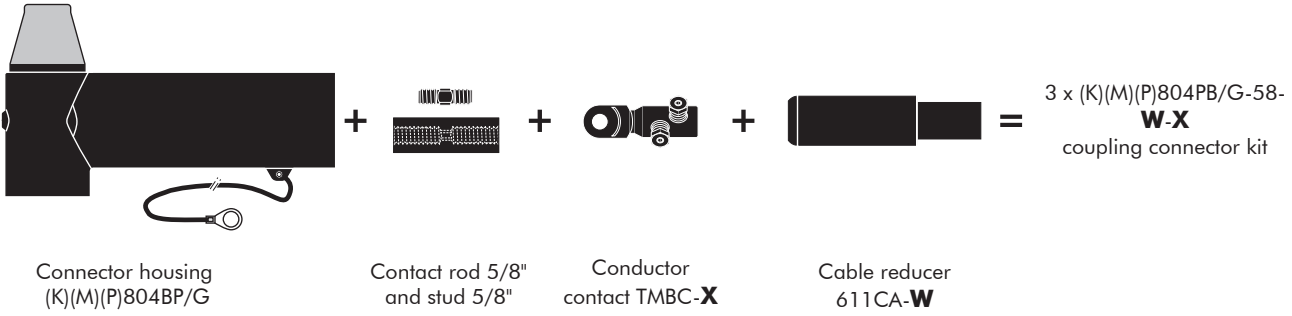

## ORDERING INSTRUCTIONS

To order the coupling connector, select the ordering part number which gives you the best centring of your core insulation diameter and substitute **X** using table X, according to your conductor size and type.

Add a 'K' for use up to 24 kV, add an 'M' for use up to 36 kV, add a 'P' for use up to 42 kV.

### Example:

The copper wire screened cable is 36 kV, 240 mm<sup>2</sup> stranded aluminium with a diameter over core insulation of 37.0 mm. Order 3 x M804PB/G-58-32-240BI2 coupling connector kit.

TABLE W

Ordering part number	Dia. over core insulation (mm)	
	min	max
3 x 804PB/G-58-15-X	16.0	22.0
3 x 804PB/G-58-19-X	20.0	26.5
3 x 804PB/G-58-22-X	23.5	31.0
3 x 804PB/G-58-27-X	28.5	37.5
3 x 804PB/G-58-32-X	34.0	42.5
3 x 804PB/G-58-37-X	39.0	48.5
3 x 804PB/G-58-43-X	45.5	56.0

TABLE X

Conductor sizes (mm <sup>2</sup> )	Aluminium and copper conductor	
	Bolted	
240	185.400UN5	
300		
400		
500		400.630UN5
630		

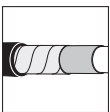

For use with copper tape screened cables.  
Order: Kit MT.

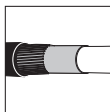

For use with copper wire screened cables. No earthing device is necessary.



For use with other cable types. Please contact our representative.



For applications outdoors and in humid climate.  
Order: +MWS.



Components can be ordered individually.



For use in potentially explosive atmospheres (for 12 kV max).  
Add -/ATEX to part number.

### APPLICATION

Surge arrester designed to protect 12, 24, 36 and 42 kV class components, including transformers, equipment, cable and accessories from high voltage surges resulting from lightning or switching. It has been designed to be used with the 784TB separable tee connectors.

### DESIGN

Surge arrester comprising:

1. Interface designed to fit the 784TB tee connector.
2. Conductive EPDM insert.
3. Conductive EPDM jacket.
4. Insulating EPDM layer moulded between the insert and the jacket.
5. Receptacle for contact rod.
6. Metal oxide valve elements.
7. Steel cap.
8. Earth connection.
9. Earth lead.

### SPECIFICATIONS AND STANDARDS

- The 800SA-58 surge arresters meet the test requirements of IEC 60099-4.
- Station class (SL);  $Q_{rs} = 1.0 \text{ As}$
- Energy absorption  $4.0 \text{ kJ/kV}_{Ur}$

### TECHNICAL CHARACTERISTICS

- This surge arrester is a metal oxide varistor surge arrester in an elbow configuration.
- Each arrester is tested for AC withstand, partial discharge and critical voltage prior to leaving the factory.

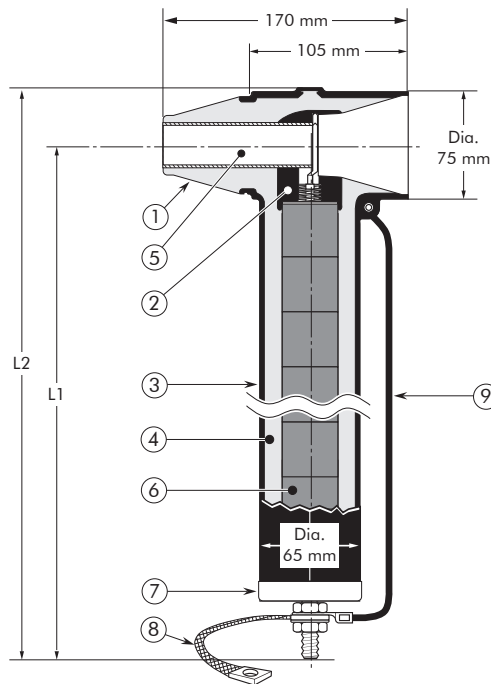

6/10 (12) kV  
 6.35/11 (12) kV  
 8.7/15 (17.5) kV  
 12/20 (24) kV  
 12.7/22 (24) kV  
 18/30 (36) kV  
 19/33 (36) kV  
 20.8/36 (42) kV

**Up to 42 kV**

**EUROMOLD®**

Surge arrester type	Nominal discharge current $I_n$ (kA)	Rated voltage $U_r$ (kV)	Max. continuous operating voltage $U_c$ (kV)	Dimensions (inches)	
				L1	L2
800SA-58-10-6N	10	6	4.8	10.63	12.20
800SA-58-10-9N	10	9	7.2	10.63	12.20
800SA-58-10-12N	10	12	9.6	10.63	12.20
800SA-58-10-15N	10	15	12.0	10.63	12.20
800SA-58-10-18N	10	18	14.4	10.63	12.20
800SA-58-10-22N	10	22	17.6	10.63	12.20
800SA-58-10-24N	10	24	19.2	14.57	16.14
800SA-58-10-27.5N	10	27.5	22.0	14.57	16.14
800SA-58-10-30N	10	30	24.0	14.57	16.14
800SA-58-10-33N	10	33	26.4	14.57	16.14
800SA-58-10-36N	10	36	28.8	14.57	16.14
800SA-58-10-42N	10	42	33.6	18.50	20.08
800SA-58-10-45N	10	45	36.0	18.50	20.08
800SA-58-10-51N	10	51	40.8	18.50	20.08

## TYPICAL APPLICATION AND DIMENSIONS

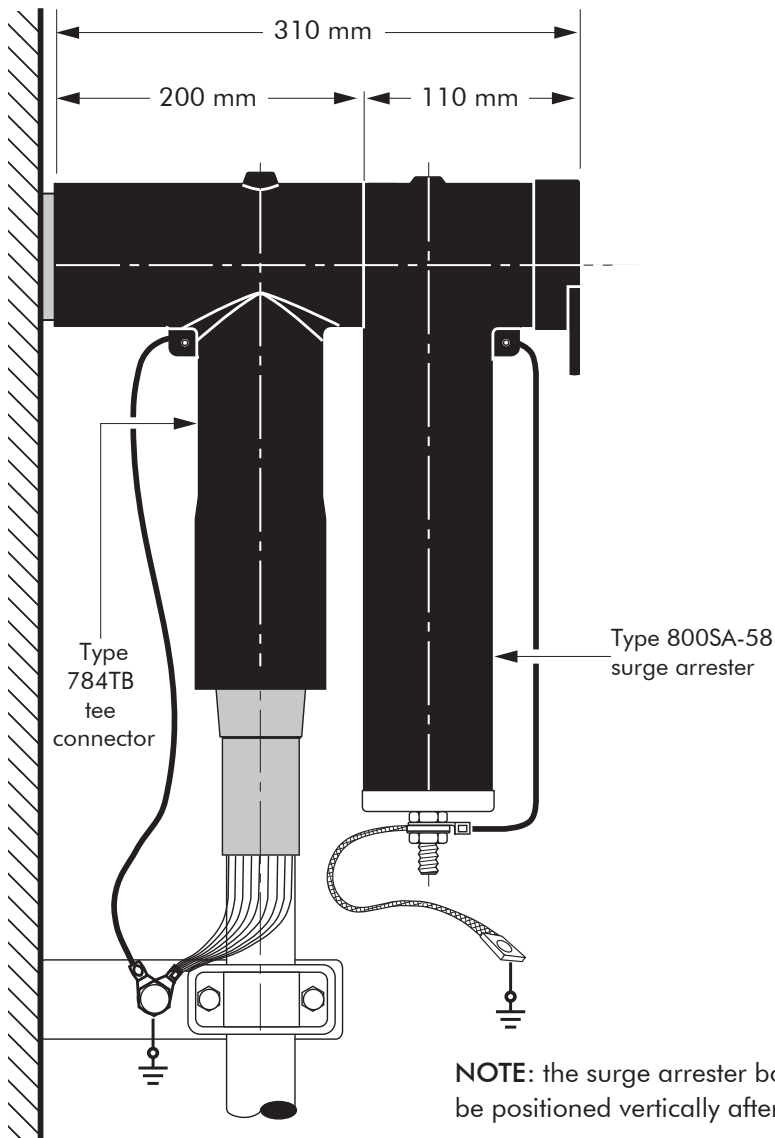

## ORDERING INSTRUCTIONS

To order the surge arrester, specify the surge arrester type, as described on previous page.

### EXAMPLE:

For a maximum continuous operating voltage (r.m.s.) of 24 kV and a nominal discharge current of 10 kA.

Order a 800SA-58-10-30N surge arrester.



For use in potentially explosive atmospheres (for 12 kV max).  
Add -/ATEX to part number.

## TECHNICAL DATA

Surge arrester type	Steep current residual voltage @ 10 kA [1/20 μs] (kV)	Lightning current residual voltage [8/20 μs] (kV)			Switching impulse residual voltage [36/90 μs] (kV)		High current impulse withstand (kA)
		@ 5 kA	@ 10 kA	@ 20 kA	@ 125 A	@ 500 A	
800SA-58-10-6N	18.5	16,2	17,2	19,3	12,6	13,2	100
800SA-58-10-9N	26.3	23	24,5	27,5	18,1	19,1	100
800SA-58-10-12N	36.3	31,5	33,6	37,1	25,1	26,5	100
800SA-58-10-15N	45.3	39,4	42	46,4	31,4	33,1	100
800SA-58-10-18N	54.4	47,3	50,4	56,4	37,7	39,7	100
800SA-58-10-22N	66.5	57,8	61,6	68,1	46	48,5	100
800SA-58-10-24N	72.5	63	67,2	75,2	50,2	53	100
800SA-58-10-27.5N	81.6	71	75,6	85	56,5	59,6	100
800SA-58-10-30N	90.7	78,8	84	94	62,8	66,2	100
800SA-58-10-33N	99.7	86,7	92,4	102,1	65	68,5	100
800SA-58-10-36N	108.8	94,5	100,8	112,7	75,3	79,4	100
800SA-58-10-40N	120.9	105,1	112	123,8	83,7	88,3	100
800SA-58-10-42N	126.9	110,3	117,6	130	87,9	92,7	100
800SA-58-10-45N	136	118,2	126	139,3	94,2	99,3	100
800SA-58-10-51N	154.1	134	142,8	160,4	106,7	112,5	100

# 750S1, 775S1 & 775T1

## INTERFACE E - 5/8" EQUIPMENT BUSHING

### APPLICATION

For use in equipment insulated with oil fluid, typically for transformers, switchgear, capacitors...

### TECHNICAL CHARACTERISTICS

Each bushing is tested for AC withstand and partial discharge prior to leaving the factory.

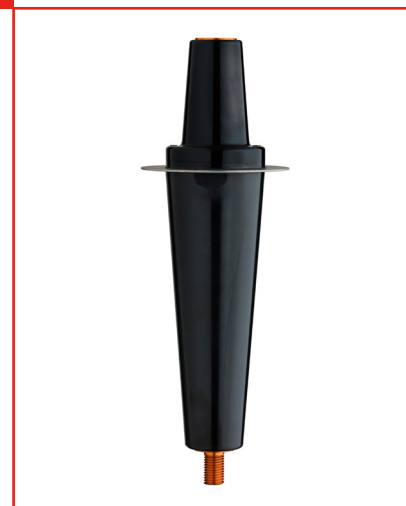

### DESIGN

The equipment bushing is a moulded epoxy insulated part in accordance with ANSI/IEEE 386 std. (5/8" threading system).

### SPECIFICATIONS AND STANDARDS

The bolted type equipment bushings 750S1, 775S1 and 775T1 meet the requirements of IEC 60137.

### ORDERING INSTRUCTIONS

To order the equipment bushing, specify the type.

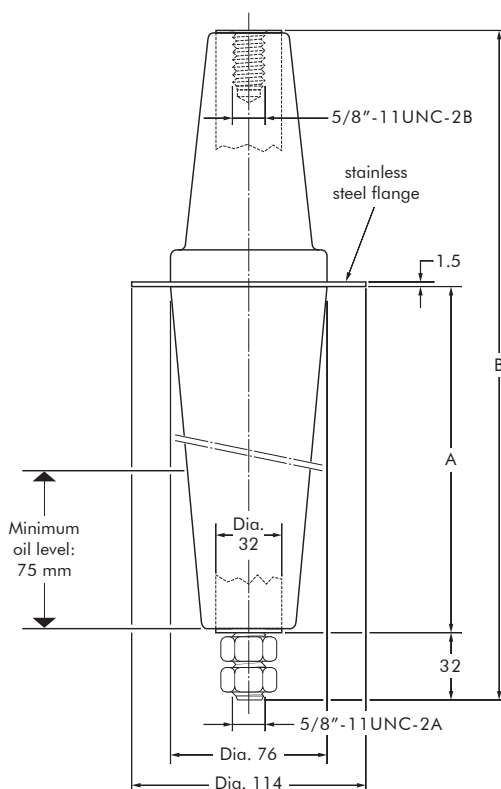

6/10 (12) kV  
6.35/11 (12) kV  
8.7/15 (17.5) kV  
12/20 (24) kV  
12.7/22 (24) kV  
18/30 (36) kV

Up to 36 kV  
800 A & 1250 A

**EUROMOLD®**

In mm.

Equipment bushing type	Voltage Ur (kV)	Current Ir (A)	Dimensions (mm)	
			A	B
750S1	36	800	75	235
775S1	36	1250	75	235
775T1	36	1250	221	378

04/2024



# FIXINGS FOR EQUIPMENT BUSHINGS

## 750S1, 775S1 AND 775T1 BUSHINGS

## BUSHING FIXING FLANGE

To order the bushing fixing flange, simply specify MK600-1.

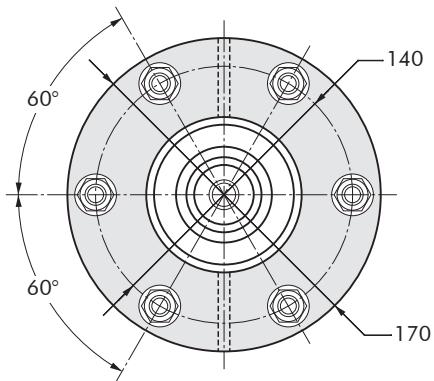
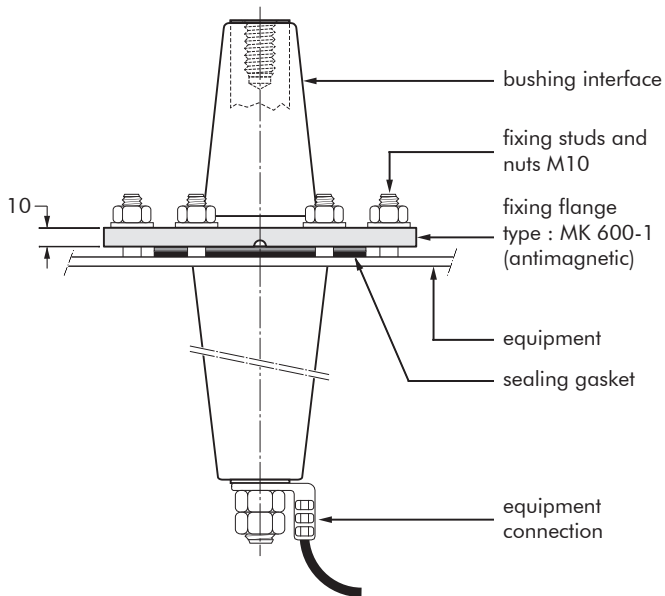

In mm.

# ACCESSORIES

## APPLICATION

For use with connectors and bushings with an INTERFACE E - 5/8" as described in IEEE std. 386.

## TECHNICAL CHARACTERISTICS

All these products, except the earthing plug, are tested for AC withstand and partial discharge prior to leaving the factory.

6/10 (12) kV  
6.35/11 (12) kV  
8.7/15 (17.5) kV  
12/20 (24) kV  
12.7/22 (24) kV  
18/30 (36) kV

**Up to 36 kV**

## 750CP & 775CP CONNECTING PLUG

For connecting two or more connectors with a type E - 5/8" interface together, thus creating a separable cable joint or a multiple cable connection to equipment.

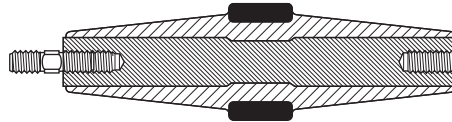

## ORDERING INSTRUCTIONS

Order 750CP for 800 A or 775CP for 1250 A applications.

## 750BE & 775BE BUSHING EXTENDER

Provides an extension piece to allow cables to stand away from equipment. Is used in conjunction with the connecting plug (750CP or 775CP).

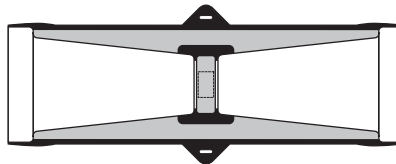

## ORDERING INSTRUCTIONS

Order 750BE for 800 A or 775BE for 1250 A applications.

## 750SOP STAND-OFF PLUG

Is designed to support and 'dead-end' connectors with a type E - 5/8" interface when removed from equipment.

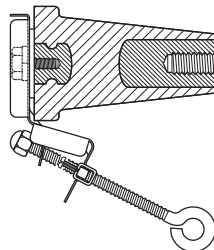

## ORDERING INSTRUCTIONS

Order 750SOP for 800 A and 1250 A applications.

04/2024

## 750GP EARTHING PLUG

Is designed to support and earth connectors with a type E - 5/8" interface when removed from equipment.

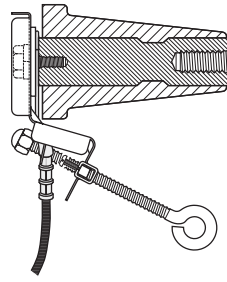

## ORDERING INSTRUCTIONS

Order 750GP for 800 A and 1250 A applications.

---

## KIT MT EARTHING KIT FOR COPPER TAPE SCREENED CABLES

Contains a finned copper braid (25 mm<sup>2</sup> - L = 500 mm), a finned copper wire for cleating and water sealing mastic.

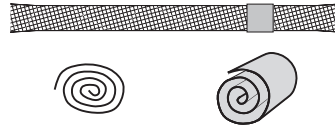

## ORDERING INSTRUCTIONS

Order Kit MT for 800 A and 1250 A applications.

# POSSIBLE ARRANGEMENTS

## 784TB

Single cable arrangement.  
 Order 784TB for 12 kV,  
 K784TB for 24 kV,  
 M784TB for 36 kV or  
 P784TB for 42 kV applications.

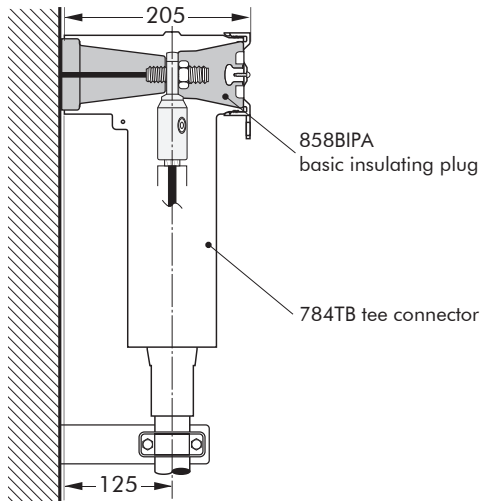

## 784TB+800PB-58

Dual cable arrangement.  
 Order 784TB+800PB-58 for 12 kV,  
 K784TB+K800PB-58 for 24 kV,  
 M784TB+M800PB-58 for 36 kV  
 or P784TB+P800PB-58 for 42 kV  
 applications.

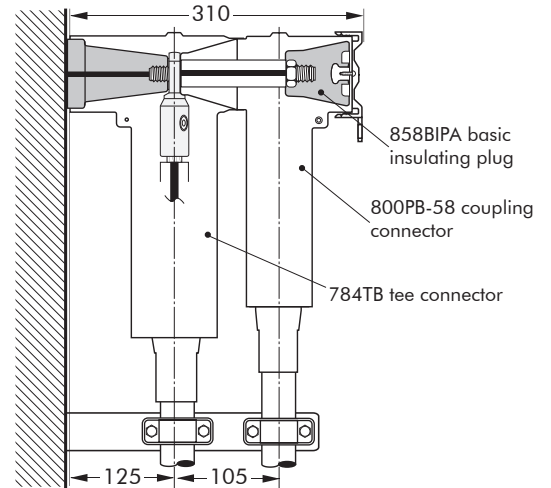

## 750BE+784TB

Connector standing away from  
 equipment.  
 Order 750BE+784TB for 12 kV,  
 K750BE+K784TB for 24 kV or  
 M750BE+M784TB for 36 kV  
 applications.

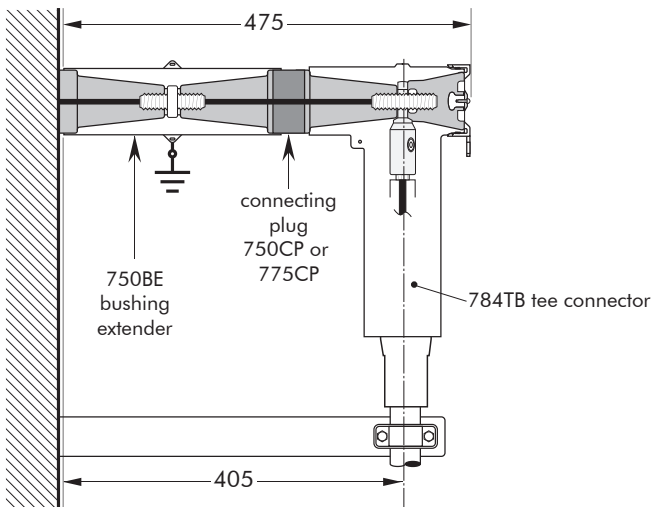

## 784TB+800SA-58

Single cable arrangement with  
 surge arrester.  
 Order 784TB+800SA-58 for 12 kV,  
 K784TB+K800SA-58 for 24 kV,  
 M784TB+M800SA-58 for 36 kV  
 or P784TB+P800SA-58 for 42 kV  
 applications.

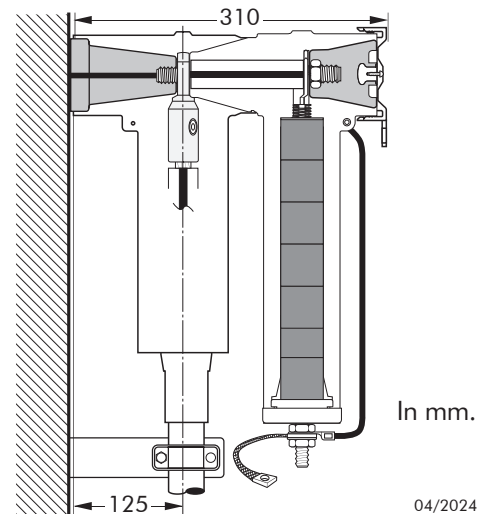

## CONNECTOR ON STAND-OFF PLUG

Order 750SOP for 12 kV,  
K750SOP for 24 kV or M750SOP  
for 36 kV applications.

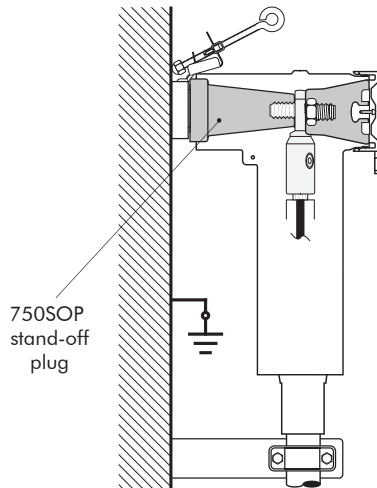

## CONNECTOR ON EARTHING PLUG

Order 750GP for 12 kV, 24 kV or  
36 kV applications.

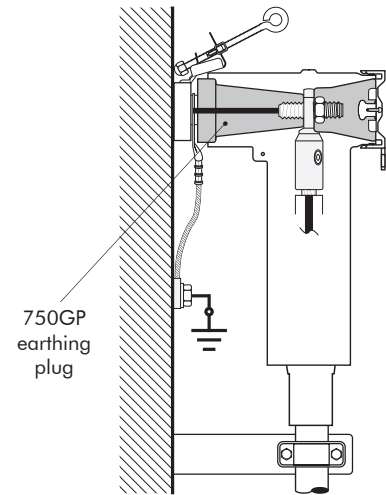

In mm.

# NOTES

---





Nexans Network Solutions N.V. - Div. Euromold  
Zuid III, Industrielaan 12, B-9320 Erembodegem  
Tel.: +32(0)53 85 02 11 • sales.euromold@nexans.com • www.euromold.be

Catalogue also available on Website and Mobile Apps



Find out more about Nexans Power Accessories.